

SUNSTONE CABINET PACKAGE - THE ALAMO

Re-Configure how you like*

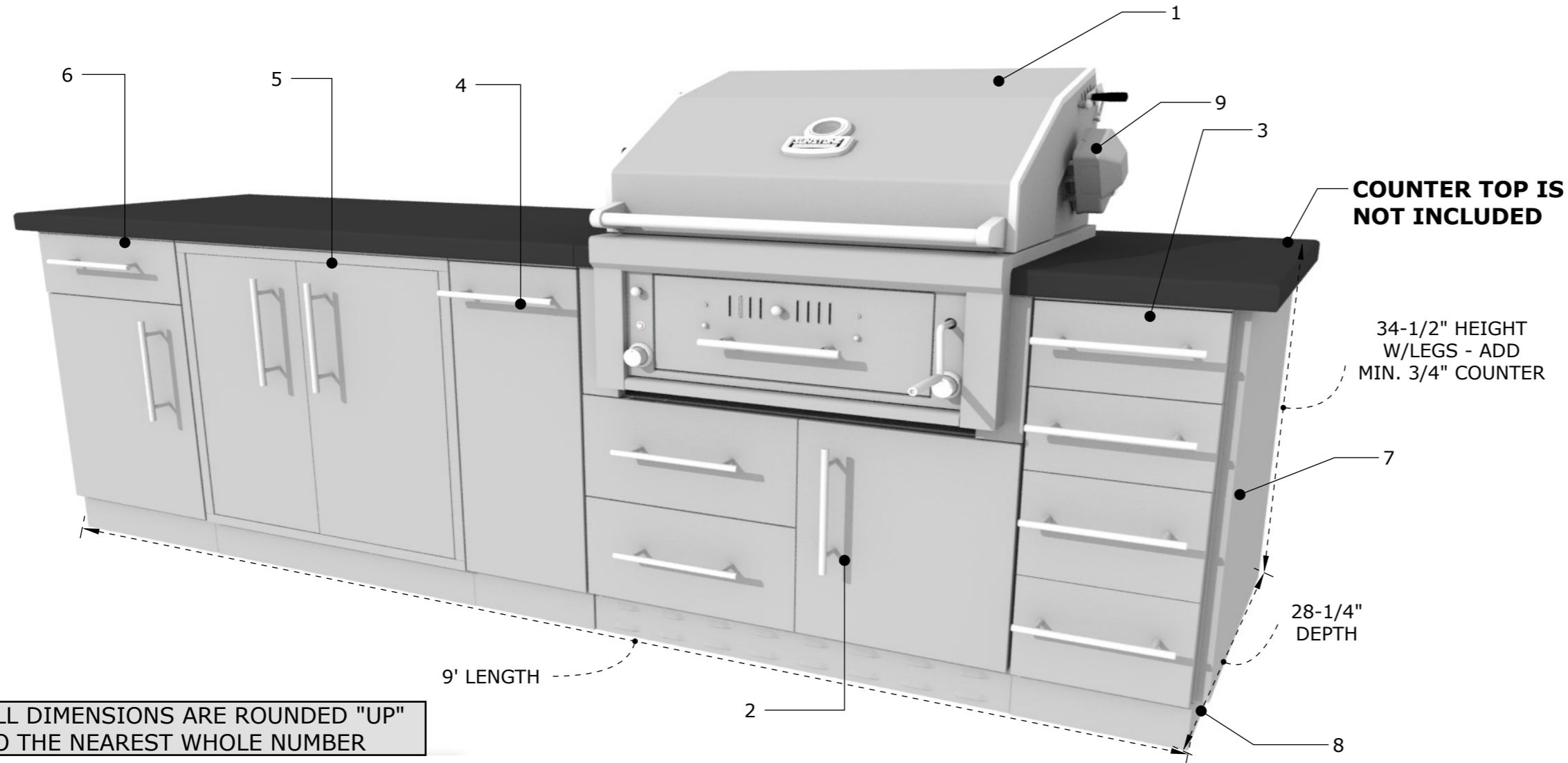

ALL DIMENSIONS ARE ROUNDED "UP" TO THE NEAREST WHOLE NUMBER

SUNSTONE METAL PRODUCTS
 16004 CENTRAL COMMERCE DR.
 PFLUGERVILLE, TEXAS 78660
 Tel: 888.934.9449
 Bus: 512.487.5116
 Fax: 512.487.7016

PRODUCT
 ALAMO 9 Feet length
 Charcoal Gas Hybrid Island

Item No. SCPALAMO

DESCRIPTION
 The Alamo offers our gas hybrid charcoal I grill & included rotisserie rod with motor. With an expansive counter and plenty of storage below with the double walled enclosed pantry cabinet, spice rack drawer with two top loading bins and the multi-drawer storage cabinets. Additionally store a propane tank or trash bin in the door drawer combo cabinet.

SPECIFICATIONS
 Length measurement is rounded up to the nearest whole number
 9' Length (includes 2 x 1" End Panels) x 28-1/4"D (w/Doors) x 34-1/2"H (w/Legs) or 35-3/4"H (w/3/4" Counter)

Equipment List - See individual product Specification Sheet for more info.

ITEM	MODEL	DESCRIPTION	QTY.
1	SUNCHSZ30	30" Gas Charcoal Hybrid Wood Burning Grill	1
2	SAC34CGDC	34" Sunstone Charcoal Grill Base Cabinet	1
3	SBC12SMD	12" 4 Multi- Drawer Cabinet	1
4	SBC12SSRD	12" Spice Rack Cabinet	1
5	SBC30DSPC	30" Dry storage cabinet	1
6	SBC18CSDL	18" Left Swing Cabinet	1
7	SCC27EP	27" Universal End Panel	2
8	SCC25KP	25" Universal Side Kickplate	2
9	P-RK-3B	3 Burner Rotisserie Assembly & Motor	1